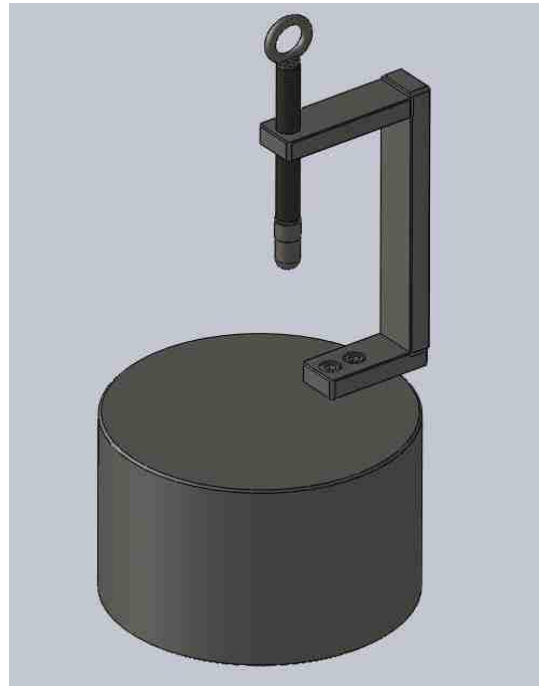

**KW-BFM-12-01**

椅子前稳定性测试模块

**Front Stability Loading Mass****Technical:**

Field of application	ANSI/BIFMA X5.1-2011 12.4 Front Stability		椅子前端稳定性		
	BS EN 1335-3 2009 Fig.B.1 Front stability loading fixture		椅子前稳定性测试模块		
Structure Characteristics	Steel make and surface chemical Blackening rust proofing treatment.				
Parameter	600N Loading Fixture, attach two pcs parts:19mm dia, rod/spherical tip ball and 19 mm da.rod with 45° taper.				
Main Parts	Part Name	Function	Material	Surface treatment	Color
	Weight block	Loading	Steel	Passivation	Black
	Spherical tip ball	Force	Stainless steel	No	Golden
	45° taper		Stainless steel	No	Primary
Installation and Transportation	Main size	400x320x410(LxWxH)mm			
Standard Accessories ( Attach )	19 mm dia, rod/spherical tip bal 1pc;				
	19 mm da.rod with 45° taper 1pc;				
Non Standard Accessories	KW-BFM-03 Form-fitting Device				

**Kingwells**

东莞市锦辉试验设备制造厂

**Kingwells Test Equipment Mfg., Ltd.**

地址:广东省东莞市南城区白马方屋沘村1巷1号

电话: 86-769-22906718 传真: 86-769-22909619

Web: www.kingwells.com

E-Mail: info@kingwells.com